

WEKOS



STUFE . STOVES . POÊLES

WEKOS

“Non vi è fuoco simile alla passione d’amore”

Wekos domina il fuoco con passione, semplicità e creatività per realizzare stufe e cucine che hanno un’anima. Con un lavoro artigianale guidato dalla cura per il dettaglio e dall’amore per il bello, vengono realizzati modelli che dialogano tra tradizione e innovazione e che rappresentano il frutto di una continua ricerca sospesa tra design e funzionalità.

Entrare nelle case, con discrezione e carattere, proponendo elementi d’arredo che espletino le loro funzioni con efficacia, nel rispetto per la natura e che personalizzino il vostro ambiente senza invadenza perché lì i protagonisti siete voi: un obiettivo ambizioso, da raggiungere anche con esperienza.

“There is no fire like passion of love”

Wekos rules over fire with passion and simplicity creating stoves and cookers with a soul.

Ours is an artisan work led by our eye for detail and our love for beauty; our creations combine tradition with innovation and are the result of our continuous commitment in research on both design and functionality.















To enter your world with discretion and yet with character, with furniture pieces that perform their duty efficiently, in the respect for nature; they characterize and blend perfectly into your spaces where you are the protagonist: this is our goal, which we ambitiously aim at achieving strong with our experience.







“Il n’est pas de feu égal à la passion amoureuse”

Wekos domine le feu avec passion, simplicité et créativité pour réaliser des poêles à bois et des cuisinières à bois qui ont une âme.

Par un travail artisanal guidé par le soin du détail et l’amour du beau, nous réalisons des modèles qui dialoguent entre tradition et innovation et qui représentent le fruit d’une recherche continue suspendue entre design et performances.

Entrer au cœur des maisons, avec discrétion et caractère, en proposant des éléments décoratifs qui jouent leur rôle avec efficacité, dans le respect de la nature et qui personnalisent votre intérieur sans être envahissants, parce que les protagonistes, c’est vous : un objectif ambitieux, que seule l’expérience permet d’atteindre.

	Stufa - Stove Poêle
	Peso netto - Net weight Poids net
	Potenza nominale (utile) - Nominal heat output Puissance nominale (utile)
	m³ riscaldabili in funzione isolamento termico - heatable m³ depending on thermal insulation - m³ chauffables en fonction de l'isolation thermique
	Scarico fumi - Flue Evacuation fumées
	Depressione media al camino - Flue draft pressure Dépression moyenne à la cheminée
	Rendimento - Efficiency Rendement
	Classe di efficienza energetica - Energy efficiency class - Classe d'efficacité énergétique
DM 186 Certificazione ambientale - Environmental certification - Certification environnementale	
	Rivestimenti - Coverings Revêtements
	Maiolica - Majolica Majolique
	Pietra serpentino boccia data - Bush-hammered serpentine Pierre serpentine bouchardée
	Pietra serpentino sabbiata - Sandblasted serpentine stone Pierre serpentine sablée
	Piastrelle - Tiles Carreaux
	Spesso metallo verniciato - Thickpainted metal Metal épais verni

	Focolare / Spazio utile focolare - Hearth / Useable space hearth Foyer / Espace utile foyer
	Spazio utile scaldavivande - Useable space wood burning oven Espace utile chaud des aliments
	Consumo legna / Lunghezza legna - Wood consumption / Length of firewood Consommation de bois / Longuer de bois
OPTIONAL	
	Ventilazione forzata - Forced air ventilation system Ventilation forcée
	Convogliazione aria posteriore - Rear air conveyer Convoyage air postérieure
	Scarico fumi posteriore - Rear flue Evacuation fumées postérieure
	Scarico fumi a DX - Flue on the right side Evacuation fumées à droite

LEGENDA



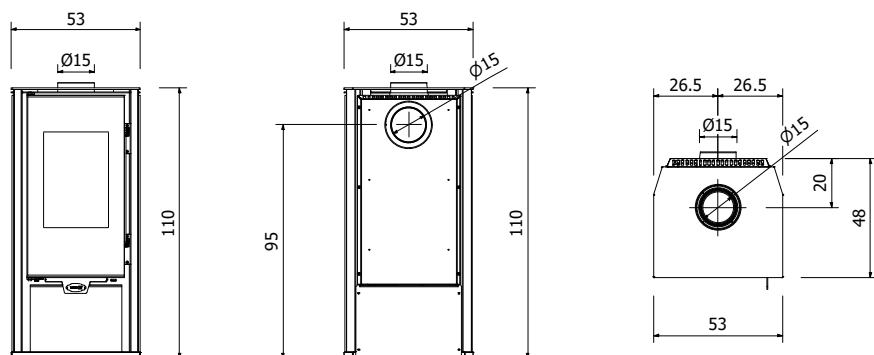









LEGEND / LÉGENDE



Una stufa a legna performante che grazie al suo design equilibrato, non è soggetta alla moda passeggera. Con il suo stile e le molte varianti del rivestimento in maiolica o pietra, si inserisce perfettamente in qualsiasi ambiente.

A high performance wood stove which, thanks to its balanced design, is not subject to fad influence. With its style and many variants of tiled or stone finish, it fits perfectly in any environment.

Un poêle à bois performant qui, grâce à son design équilibré, n'est pas soumis à la mode passagère. Avec son style e les nombreuses variantes du revêtement en faïence ou en pierre, ce poêle s'intègre parfaitement dans tout environnement.

 S 80				
 167 kg				
 9,2 kW				
 180 ÷ 320 m³				
 $\varnothing 15$ cm				
 11 Pa				
 84 %				
 A+				
DM 186 ★ ★ ★ ★				
 ceramica refrattaria refractory ceramics céramique réfractaire	36 cm 33 cm ↘ 32 cm			
 M PS				
 2,5 kg/h – cm 25				
OPTIONAL				
VF	CP			
✓	✓	✓		



S 80





CRETA

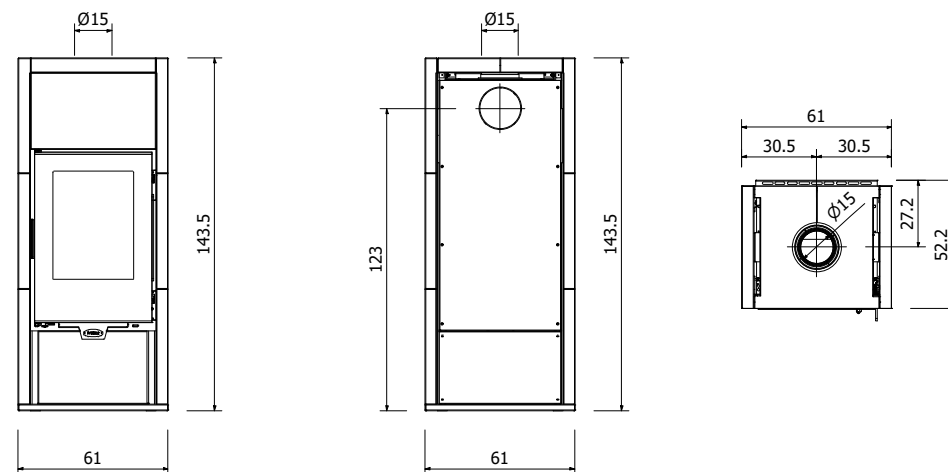

Stufa a legna di grande potenza e dall'estetica intramontabile. La sua importante massa di pietra naturale permette di avere una straordinaria emissione di calore confortevole anche dopo molte ore che si è spento il fuoco. Disponibile a richiesta la versione con accumulo interno plus.

Extremely powerful woodstove with a timeless aesthetics. Its considerable natural stone mass allows for an extraordinary, comfortable heat emission that lasts even many hours after the fire has burned out. Available on request even the version with "internal heat accumulation plus".

Un poêle à bois à grande puissance et à l'esthétique intemporelle. Sa masse considérable en pierre naturelle consent d'obtenir une émission extraordinaire de confortable chaleur même après plusieurs heures que le feu s'est éteint. Disponible, sur demande, la version avec accumulation interne plus.

🔥 SP 300											
📊	405 kg / 481 kg Plus										
⚡	9,2 kW										
m ³	180 ÷ 320 m ³										
🔥	Ø 15 cm										
↕	11 Pa										
η	84 %										
🏠	A+										
DM 186	★ ★ ★ ★										
🔥	ceramica refrattaria refractory ceramics céramique réfractaire										
	35 cm 38 cm 35 cm										
📄	PS										
🔥	2,5 kg/h – cm 33										
OPTIONAL	<table border="1"> <tr> <td>VF</td> <td>CP</td> <td>🔥</td> <td></td> <td></td> </tr> <tr> <td>✓</td> <td>✓</td> <td>✓</td> <td></td> <td></td> </tr> </table>	VF	CP	🔥			✓	✓	✓		
VF	CP	🔥									
✓	✓	✓									



CRETA MAXI PIETRA

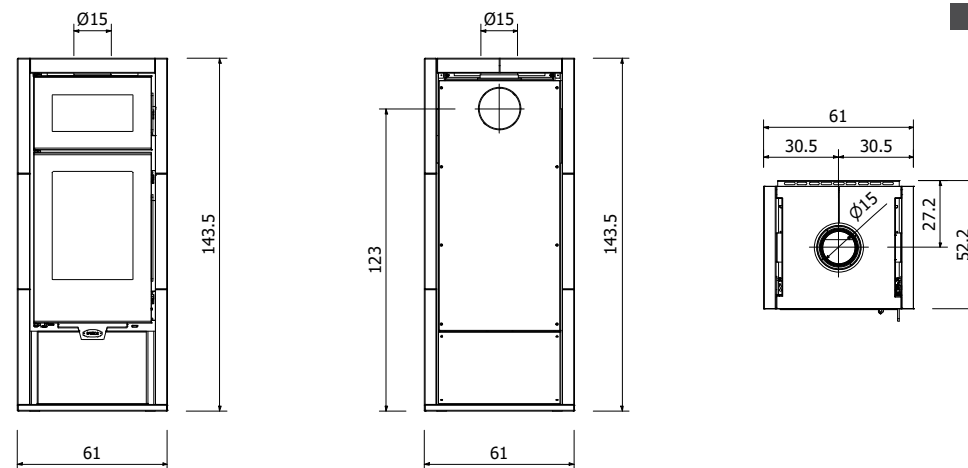

Splendida stufa a legna con vano scaldavivande. Mentre nel focolare inferiore danzano le fiamme, nel vano superiore cuociono pietanze dal sapore unico. L'importante rivestimento in pietra naturale, permette un accumulo di calore che rende estremamente confortevole la vostra amata casa.

Gorgeous woodstove with food warmer compartment. While in the lower firebox the flames are dancing, in the upper compartment dishes of unique flavor are being cooked. The important natural stone cladding allows for an accumulation of heat, making your beloved home extremely comfortable.

Un poêle à bois superbe avec boîte réchaud pour aliments. Tandis que dans le foyer inférieur les flammes dansent, dans la boîte supérieure des plats au saveur unique sont en train de mijoter. Le riche revêtement en pierre naturelle consent une accumulation de chaleur qui rendra extrêmement confortable votre maison bien-aimée.

🔥 SF 200											
📦	407 kg										
⚡	9,2 kW										
m ³	180 ÷ 320 m ³										
🔥	Ø 15 cm										
↕	11 Pa										
η	84 %										
🏠	A+										
DM 186	★★★★										
🔥	ceramica refrattaria refractory ceramics céramique réfractaire										
🍲	18 cm 38 cm ↙ 33 cm										
🔥	PS										
🔥	2,5 kg/h – cm 33										
OPTIONAL	<table border="1"> <tr> <td>VF</td> <td>CP</td> <td>🔥</td> <td></td> <td></td> </tr> <tr> <td>✓</td> <td>✓</td> <td>✓</td> <td></td> <td></td> </tr> </table>	VF	CP	🔥			✓	✓	✓		
VF	CP	🔥									
✓	✓	✓									

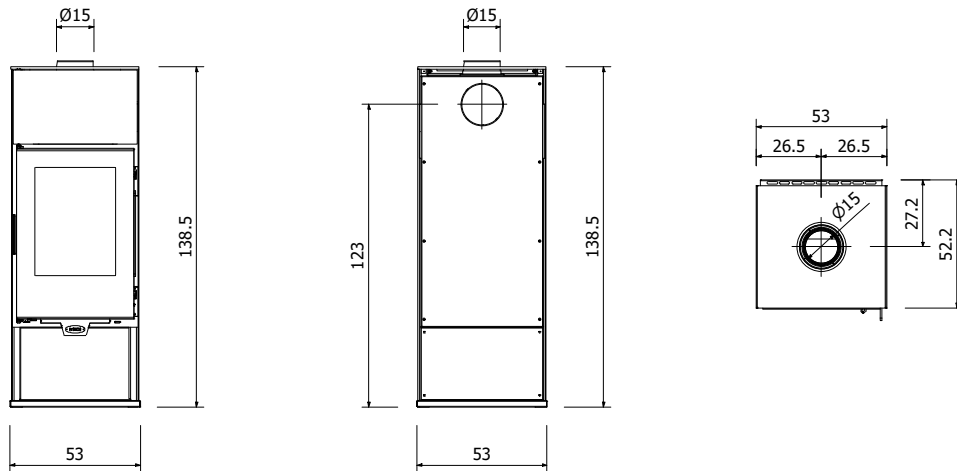

Stufa a legna dal design essenziale che si integra armoniosamente nell'ambiente. Disponibile a richiesta la versione con accumulo interno plus: 76 Kg. di pietra serpentino posizionati nella parte alta della stufa che aumentano la capacità di rilasciare calore anche a stufa spenta.

Essential designed wood stove that integrates harmoniously into the location. Available on request in the version with internal plus accumulation: 76 kg of serpentine stone positioned in the upper part of the stove which increases the capacity to release heat even when the stove is out.

Poêle à bois au design essentiel qui s'intègre harmonieusement dans l'environnement. Disponible sur demande, la version avec une masse accumulante: 76 Kg. de pierre serpentine placés dans la partie supérieure du poêle augmentent la capacité de libérer de la chaleur même lorsque le poêle est éteint.

 S 400				
 297 kg / 303 kg Plus				
 9,2 kW				
 180 ÷ 320 m³				
 Ø 15 cm				
 11 Pa				
 84 %				
 A+				
DM 186 ★ ★ ★ ★				
 ceramica refrattaria refractory ceramics céramique réfractaire	35 cm 38 cm 35 cm			
 				
 2,5 kg/h – cm 33				
OPTIONAL	 VF	 CP		
	✓	✓	✓	



CRETA METAL



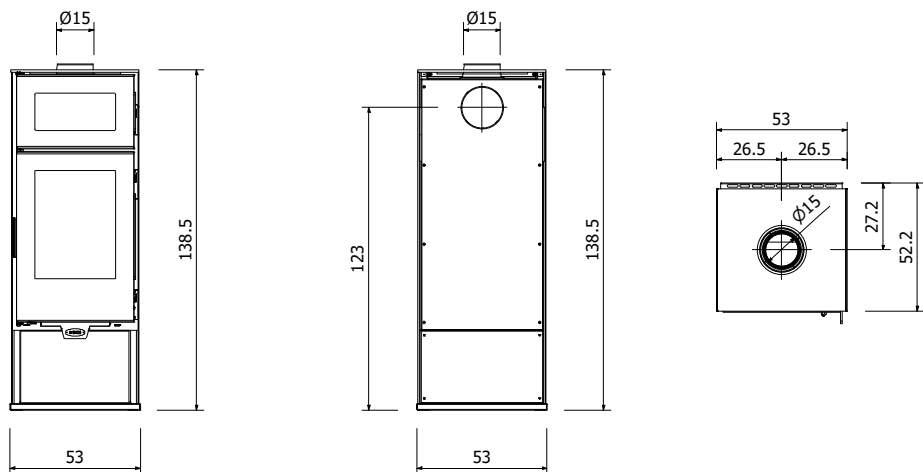















Stufa a legna dal design puro ed elegante che si inserisce perfettamente in qualsiasi tipo di ambientazione. Mentre nel grande focolare inferiore la legna arde con grazia, nel vano superiore i vostri cibi diventano sfiziosi e saporiti. La vostra casa durante tutto l'inverno diventerà calda e confortevole.

With its pure and elegant design, this woodstove fits perfectly into any kind of environment. While in the lower large fireplace logs are gracefully burning, in the top compartment your foods become tasty and flavorful. Your home will be warm and cozy all winter through.

Poêle à bois avec un design pur et élégant qui s'intègre parfaitement dans tout environnement. Tandis que dans le grand foyer inférieur le bois est en train de brûler gracieusement, dans le compartiment supérieur vos aliments deviennent délicieux et savoureux. Votre maison pendant tout l'hiver sera donc chaude et confortable.

	SF 100				
	245 kg				
	9,2 kW				
	180 ÷ 320 m³				
	Ø 15 cm				
	11 Pa				
	84 %				
	A+				
DM 186	*****				
	ceramica refrattaria refractory ceramics céramique réfractaire	35 cm 38 cm / 35 cm			
	18 cm 38 cm / 33 cm				
					
	2,5 kg/h – cm 33				
OPTIONAL	VF	CP			
	✓	✓	✓		



CRETA MAXI METAL





FIAMMETTA

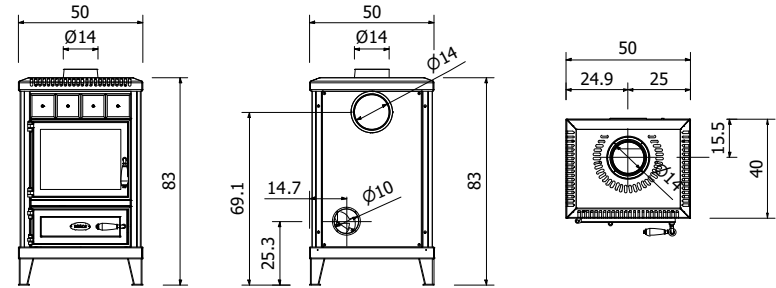

La stufa Fiammetta nonostante le sue dimensioni contenute, vi regalerà tanto piacevole calore nelle più fredde giornate invernali o nelle umide serate autunnali. Disponibile con vari tipi di rivestimento che la rende adatta a molte tipologie di ambientazione.

Despite its small size, Fiammetta will give you plenty of warmth on the coldest winter days or in the rainy autumn evenings. Available with various types of cladding making it suitable for many different settings.

Le poêle Fiammetta, malgré ses dimensions compactes, vous donnera tant de chaleur et de confort pendant les jours froids d'hiver ou les soirées humides d'automne. Disponible avec différents types de revêtement qui le rendent indiqué à nombreux styles d'ameublement.

🔥 S003											
📊 Kg	116 kg										
⚡ kW	6,6 kW										
m ³	140 ÷ 220 m ³										
🔥	14 Ø cm										
↕	11 Pa										
η	79,4 %										
🏠	A										
DM 186	****										
🔥	ghisa cast iron / fonte 33 cm 31 cm ↙ 25 cm										
📏	M PB PS 10x10										
🔥	2 kg/h – cm 25										
OPTIONAL	<table border="1"> <tr> <td>VF</td> <td>CP</td> <td>🔥</td> <td></td> <td></td> </tr> <tr> <td>×</td> <td>×</td> <td>✓</td> <td></td> <td></td> </tr> </table>	VF	CP	🔥			×	×	✓		
VF	CP	🔥									
×	×	✓									



ESMERALDA

C/CORRIMANI

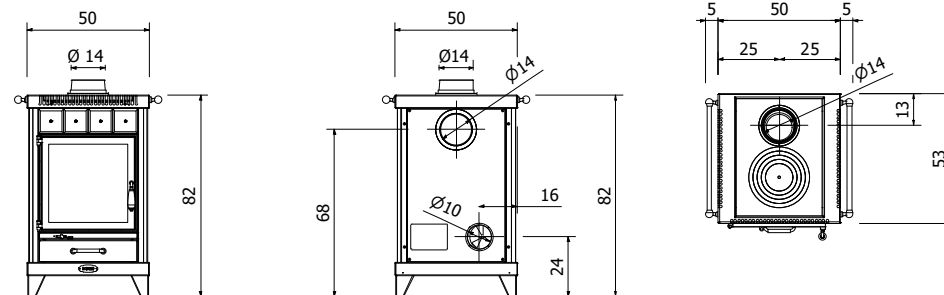

L'Esmeralda si caratterizza per la grande porta vetrata che permette una perfetta visione delle fiamme scoppiettanti e dalla piastra superiore con cerchi, pronta a cucinare le vostre pietanze preferite. Perfetta anche per le case vacanza di montagna, ecc.

Esmeralda is characterized by a large glass door allowing a perfect view of the crackling flames and by an upper plate with circles, perfect for cooking your favorite dishes. Most suitable also for a mountain vacation home, etc....

Esmeralda se caractérise par la grande porte vitrée qui permet une vision parfaite du feu crépitant et par la plaque supérieure avec des cercles, prête à cuire vos plats préférés. Ce poêle est parfait même pour des maisons pour les vacances à la montagne, etc.

🔥 S 036									
📊 Kg	136 kg								
⚡ kW	6,6 kW								
m ³	140 ÷ 220 m ³								
🔥	14 Ø cm								
⬇️⬆️	11 Pa								
η	79,4 %								
🏠	A								
DM 186	****								
🔥	ghisa cast iron / fonte 33 cm 31 cm ↙ 35 cm								
📏	M PB PS 10x10								
🌿	2 kg/h – cm 25								
OPTIONAL	<table border="1"> <tr> <td>VF + CP</td> <td>🔥</td> <td></td> <td></td> </tr> <tr> <td>✓</td> <td>✓</td> <td></td> <td></td> </tr> </table>	VF + CP	🔥			✓	✓		
VF + CP	🔥								
✓	✓								





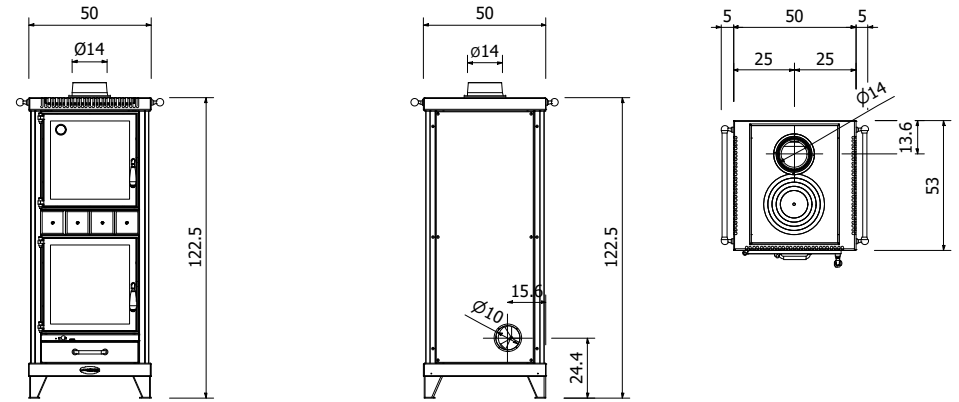









ESMERALDA MAXI C/CORRIMANI



Stufa a legna compatta ma dalle generose prestazioni. Grande focolare con ampia porta vetrata, capiente vano di cottura sempre pronto a sfornare deliziose pietanze e top superiore con cerchi che vi consentirà di tenere in caldo tanti gustosi manicaretti.

Compact wood stove yet with high performances. Wide firebox with big glass door, large cooking compartment always ready to cook delicious dishes and upper plate with circles allowing you to keep warm all your tasty delicacies.

Poêle à bois compact, mais aux performances extraordinaires. Grand foyer avec large porte vitrée, compartiment cuisson à grande capacité toujours prêt à défourner des plats délicieux ainsi que plaque supérieure avec cercles qui vous permettra de garder bien chauds beaucoup de plats savoureux.

 S 037				
	184 kg			
	6,6 kW			
m³	140 ÷ 220 m ³			
	14 Ø cm			
	11 Pa			
η	79,4 %			
	A			
DM 186	***			
	ghisa cast iron / fonte			
	33 cm 26 cm / 40 cm			
	M PB PS 10x10			
	2 kg/h – cm 25			
OPTIONAL	VF + CP			
				



PARISIEN

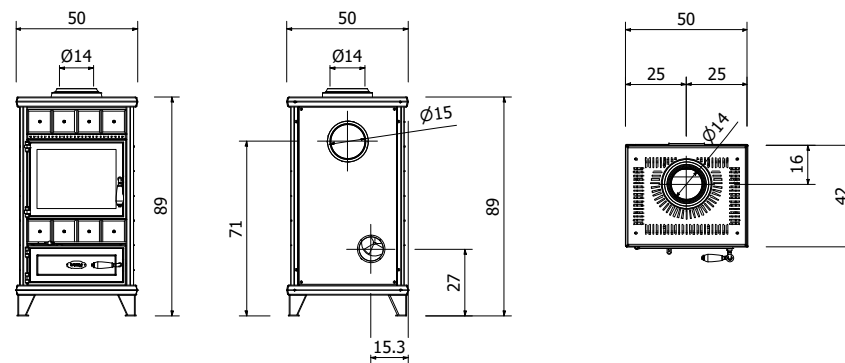

La Parisien è una delle stufe “storiche” della gamma Wekos e una delle più vendute. Le dimensioni contenute la rendono adatta a qualsiasi ambientazione e le molte varianti dei rivestimenti disponibili soddisfano anche i più esigenti.

Parisien is one of the “historic” stoves in the Wekos range and one of the most sold. Its small size makes it suitable for any environment and its numerous available finishes and cladding options will satisfy even the most demanding customers.

Parisien est l'un des poêles « historiques » de la gamme Wekos et l'un des plus vendus. Sa taille petite le rend indiqué à tout ambiance et les nombreuses variantes de revêtements disponibles satisfont même les clients les plus exigeants.

🔥 S 004											
📊 Kg	114 kg										
🔥 kW	6,6 kW										
📏 m ³	140 ÷ 220 m ³										
🔥 14 Ø cm	14 Ø cm										
📏 11 Pa	11 Pa										
η	79,4 %										
🏠 A	A										
DM 186	★ ★ ★ ★										
🔥 ghisia cast iron / fonte	33 cm 31 cm / 25 cm										
📏 M PB PS 10x10	10x10										
🔥 2 kg/h – cm 25	2 kg/h – cm 25										
OPTIONAL	<table border="1"> <tr> <td>VF</td> <td>CP</td> <td>🔥</td> <td></td> <td></td> </tr> <tr> <td>✓</td> <td>✓</td> <td>✓</td> <td></td> <td></td> </tr> </table>	VF	CP	🔥			✓	✓	✓		
VF	CP	🔥									
✓	✓	✓									



PARISIEN



ESMERALDA



ESMERALDA



ESMERALDA MAXI



AVVENTURINA

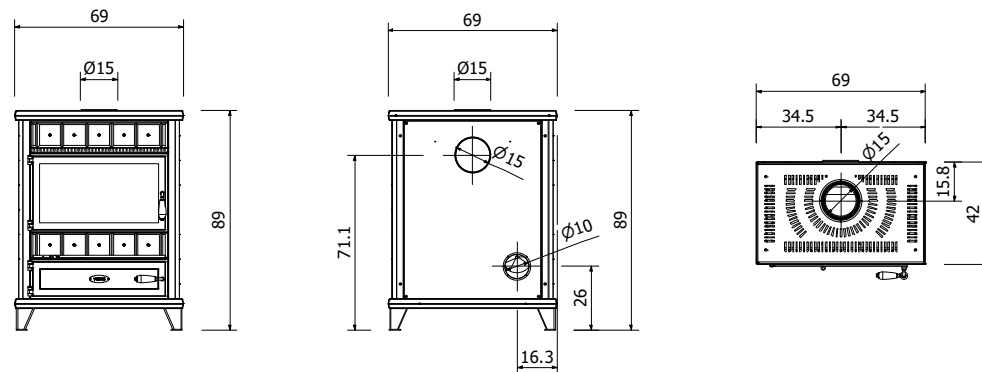

Questa stufa grazie alla ridotta profondità può essere posizionata in tutte quelle situazioni dove lo spazio è ridotto. Il largo focolare permette l'utilizzo di ceppi di legna lunghi fino a 50 cm e il grande vetro vi farà ammirare il fuoco scoppiettante.

Thanks to its reduced depth, this large woodstove is ideal for space-constraint rooms. Its large firebox allows the use of logs up to 50 cm long while its big glass will show you the crackling fire.

Ce poêle, grâce à sa profondeur réduite, peut être positionné dans tous les aménagements où l'espace est réduit. Le large foyer permet l'utilisation de bûches jusqu'à 50 cm et la grande porte vitrée vous consentira d'admirer le feu crépitant.

🔥 S 039											
📊 Kg	143 kg										
🔥 kW	9,2 kW										
m ³	180 ÷ 320 m ³										
🔥	15 Ø cm										
📏	11,9 Pa										
η	82,7 %										
🏠	A+										
DM 186	★★★★										
🔥	ghisa cast iron / fonte 31 cm 51 cm ↙ 26 cm										
📏	M PB PS 10x10										
🔥	2,6 kg/h – cm 33/50										
OPTIONAL	<table border="1"> <tr> <td>VF</td> <td>CP</td> <td>🔥</td> <td></td> <td></td> </tr> <tr> <td>✓</td> <td>✓</td> <td>✓</td> <td></td> <td></td> </tr> </table>	VF	CP	🔥			✓	✓	✓		
VF	CP	🔥									
✓	✓	✓									



AVVENTURINA

C/PIASTRA E CORRIMANI

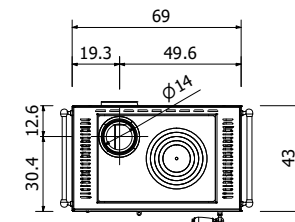
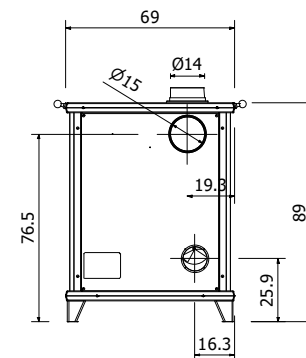
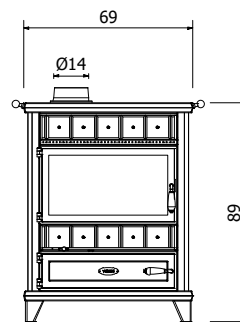

Stufa dall'aspetto classico ma che si integra perfettamente in qualsiasi tipo di arredamento grazie alla possibilità di scegliere varie tipologie di rivestimento. La sua peculiarità è la piastra di cottura presente sul top che consente di cucinare gustose pietanze.

Classic-style stove yet perfectly integrating into any kind of furnishing thanks to the wide choice of different types of finishing. Its distinctiveness is the upper cooking plate allowing to cook tasty dishes.

Poêle à l'aspect classique mais qui s'intègre parfaitement dans tout type d'intérieur, grâce à la possibilité de choisir de différents types de revêtement. Sa particularité est la plaque de cuisson sur la partie supérieure qui vous permet de cuire des aliments savoureux.

🔥 S 040				
🏋️	150 kg			
⚡	9,2 kW			
m ³	180 ÷ 320 m			
🔥	14 Ø cm			
⬇️⬆️	11,9 Pa			
η	82,7 %			
🏠	A+			
DM 186	***			
🔥	ghisa cast iron / fonte 31 cm 51 cm 26 cm			
🔥	M PB PS 10x10			
🔥	2,6 kg/h – cm 33/50			
OPTIONAL	VF + CP	🔥	DX	
	✓	✓	✓	



AVVENTURINA MAXI

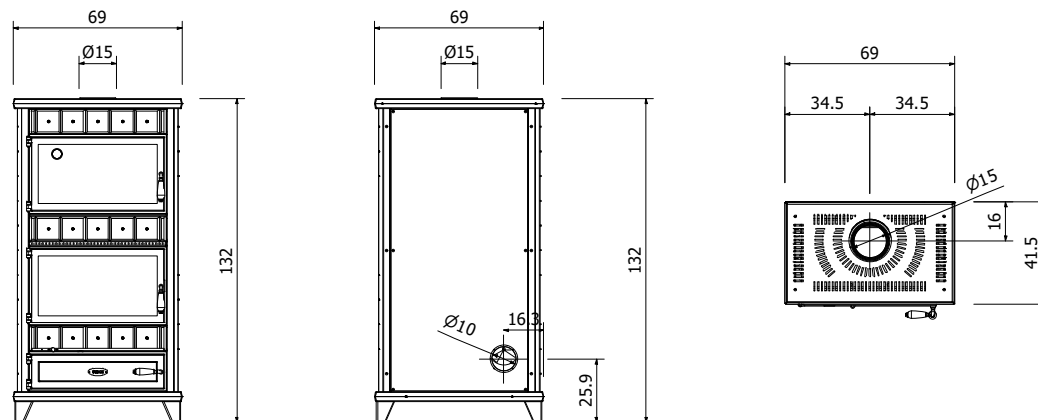

Stufa a legna larga e poco profonda, adatta ad essere inserita in ambienti dove lo spazio è ridotto. Il largo focolare accoglie ceppi fino a 50 cm mentre il vano superiore è sempre pronto a sfornare pietanze sfiziose e cotte a puntino.

Large and shallow wood stove, suitable for environments where space is limited. Its large firebox accommodates logs up to 50 cm while its upper plate is always ready to prepare delicious and perfectly cooked dishes.

Poêle à bois large et peu profond, indiqué pour être inséré dans les aménagements où l'espace est réduit. Le large foyer accueille des bûches jusqu'à 50 cm tandis que le compartiment supérieur est toujours prêt à cuire à la perfection des plats délicieux.

🔥 S 041	
📊 Kg	194 kg
⚡ kW	9,2 kW
m ³	180 ÷ 320 m ³
🔥	15 Ø cm
📏	11,9 Pa
η	82,7 %
🏠	A+
DM 186	***
🔥	ghisa cast iron / fonte
🍲	27 cm 40 cm — 28 cm
📏	31 cm 51 cm — 26 cm
📏	M PB PS 10x10
🔥	2,6 kg/h – cm 33/50
OPTIONAL	VF CP
	✓ ✓ ✗



VENETIEN

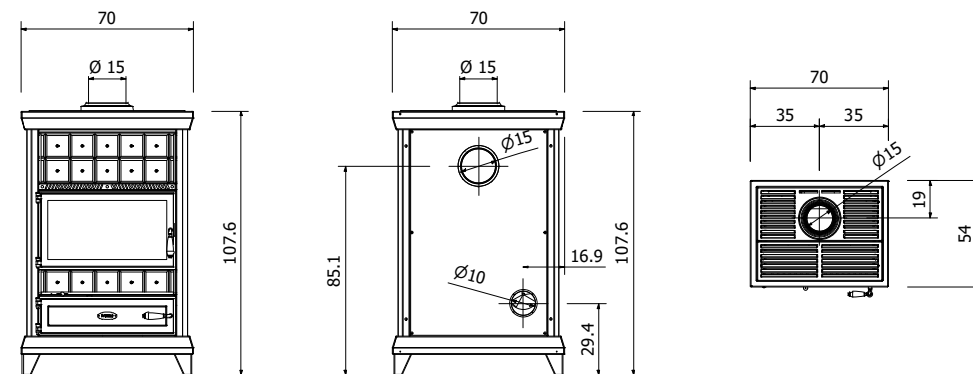

La stufa Venetien conserva un design tradizionale ma, grazie alle sue forme equilibrate e alle molteplici varietà dei rivestimenti proposti, si integra perfettamente in qualsiasi tipo di ambientazione. Offre prestazioni caloriche elevate mentre la grande porta vetrata dona una piacevole visione delle fiamme danzanti.

The Venetien woodstove retains a traditional design but, thanks to its balanced forms and its multiple varieties of proposed claddings, it perfectly matches with any type of setting. It ensures a high calorific performance while its large glass door gives a nice view of the dancing flames.

Le poêle Venetien conserve un design traditionnel mais, grâce à ses formes équilibrées et aux multiples variétés de finitions disponibles, s'intègre parfaitement dans tous les décorations d'intérieurs. Le poêle offre une haute performance calorique tandis que la grande porte vitrée donne une vue agréable sur les flammes dansantes.

🔥 SPB 015											
📦	230 kg										
⚡	9,2 kW										
m ³	180 ÷ 320 m ³										
🔥	15 Ø cm										
↕	11,9 Pa										
η	82,7 %										
🏠	A+										
DM 186	****										
🔥	ghisa cast iron / fonte 33 cm 50 cm / 35 cm										
📏	M PB PS 10x10										
🔥	2,6 kg/h – cm 33/50										
OPTIONAL	<table border="1"> <tr> <td>VF</td> <td>CP</td> <td>🔥</td> <td></td> <td></td> </tr> <tr> <td>✓</td> <td>✓</td> <td>✓</td> <td></td> <td></td> </tr> </table>	VF	CP	🔥			✓	✓	✓		
VF	CP	🔥									
✓	✓	✓									



VENETIEN MAXI

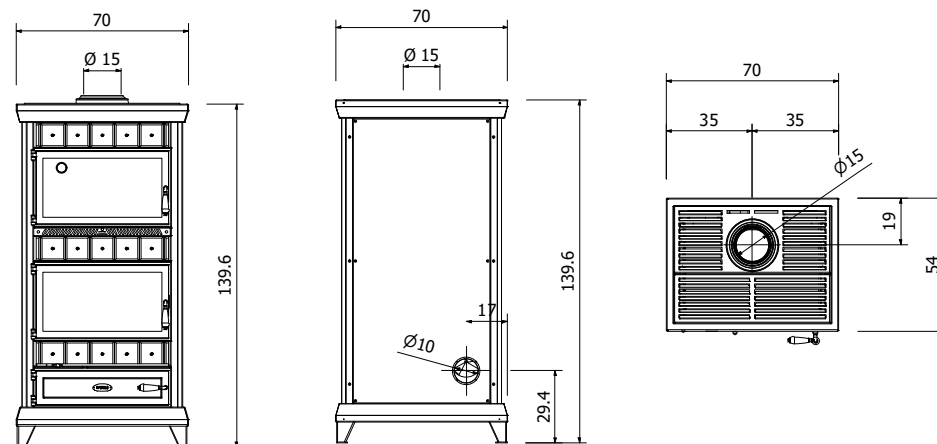

Linea classica, solida e molto potente. Questa grande stufa a legna è in grado di donarvi tanto calore e tante pietanze gustose perfettamente cotte nel grande vano superiore. Il grande focolare permette l'utilizzo di ceppi fino a 50 cm.

Classic line, solid and very powerful. This large woodstove will give you so much heat and plenty of tasty dishes perfectly cooked in its wide upper compartment. Its large firebox allows the use of logs up to 50 cm.

Ligne classique, solide et très puissante. Ce grand poêle à bois pourra vous donner tant de chaleur ainsi que beaucoup de plats délicieux parfaitement cuits dans son grand compartiment supérieur. Le grand foyer permet l'utilisation de bûches jusqu'à 50 cm.

🔥 SM 004											
📊 Kg	290 kg										
⚡ kW	9,2 kW										
m ³	180 ÷ 320 m ³										
🔥	15 Ø cm										
📏	11,9 Pa										
η	82,7 %										
🏠	A+										
DM 186	★ ★ ★ ★										
🔥	ghisa cast iron / fonte 33 cm 50 cm ↙ 35 cm										
🍲	26 cm 39 cm ↙ 40 cm										
📏	M PB PS 10x10										
🔥	2,6 kg/h – cm 33/50										
OPTIONAL	<table border="1"> <tr> <td>VF</td> <td>CP</td> <td>🔥</td> <td></td> <td></td> </tr> <tr> <td>✓</td> <td>✓</td> <td>✗</td> <td></td> <td></td> </tr> </table>	VF	CP	🔥			✓	✓	✗		
VF	CP	🔥									
✓	✓	✗									



VALMALENCO

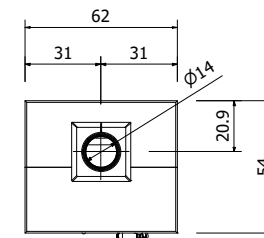
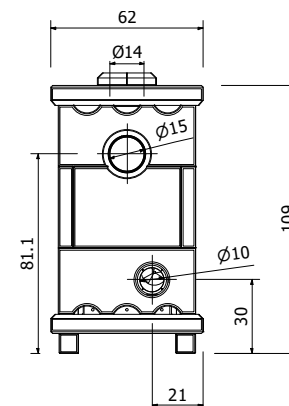
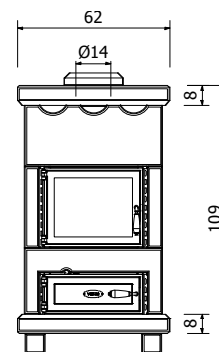

Pietra sabbata: fronte e retro

Questa stufa a legna è una versione media della collezione Wekos in pietra serpentino d'accumulo. L'importante massa di pietra e il robusto focolare sono garanzia di tanti anni di sano e gradevole calore che allieterà anche i più freddi inverni.

This woodstove is a medium version of the Wekos collection of serpentine stone accumulation models. Its important mass of stone and a sturdy firebox are a guarantee of many years of healthy and comfortable warmth that will brighten up even the coldest winters.

Ce poêle à bois est une version moyenne parmi la collection Wekos de pierre serpentine d'accumulation. Sa masse considérable en pierre et son solide foyer représentent une garantie de plusieurs années de chaleur saine et confortable qui remplira de bonheur votre maison même pendant les hivers les plus froids.

🔥 SPB 019	
📊 kg	465 kg
🔥 kW	6,6 kW
📏 m³	140 ÷ 220 m³
🔥 Ø	14 Ø cm
📏 Pa	11 Pa
📏 η	79,4 %
🏠 A	A
DM 186	★ ★ ★ ★
🔥 ghisa cast iron / fonte	33 cm 31 cm ↘ 25 cm
📏 PB PS	
🔥 2 kg/h - cm 25	
OPTIONAL	
	VF CP
	✗ ✗ ✓



AURINA

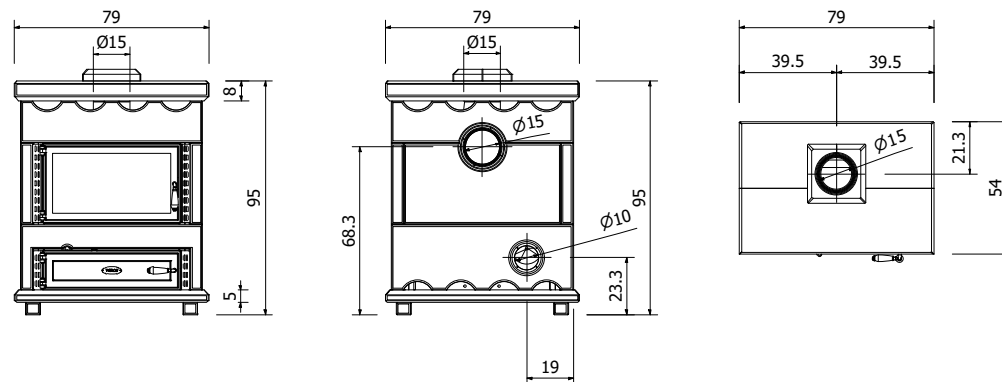

La stufa a legna Aurina, con il suo massiccio rivestimento in pietra serpentino e con decori a scelta, vi donerà tanto e confortevole calore anche nelle più fredde giornate invernali. Il capiente focolare permette di inserire ceppi di legna anche di 50 cm per garantire tante ore di fuoco.

The Aurina woodstove, with its massive cladding of serpentine stone and its various possible finishes, will give you so much comfort and warmth even on the coldest winter days. Its large firebox will allow you to load logs of up to 50 cm to ensure plenty of hours of fire.

Le poêle à bois Aurina, avec son solide revêtement en pierre serpentine et ses finitions au choix, vous donnera tant de chaleur confortable même dans les jours les plus froids d'hiver. Son foyer spacieux consent le chargement de bûches jusqu'à 50 cm assurant de nombreuses heures de feu.

🔥 SPB 021											
📊 Kg	468 kg										
🔥 kW	9,2 kW										
m ³	180 ÷ 320 m ³										
🔥	15 Ø cm										
↕	11,9 Pa										
η	82,7 %										
🏠	A+										
DM 186	*****										
🔥	ghisa cast iron / fonte 31 cm 51 cm ↙ 26 cm										
🔥	PB PS										
🔥	2,6 kg/h – cm 33/50										
OPTIONAL	<table border="1"> <tr> <td>VF</td> <td>CP</td> <td>🔥</td> <td></td> <td></td> </tr> <tr> <td>✗</td> <td>✗</td> <td>✓</td> <td></td> <td></td> </tr> </table>	VF	CP	🔥			✗	✗	✓		
VF	CP	🔥									
✗	✗	✓									



AURINA MAXI

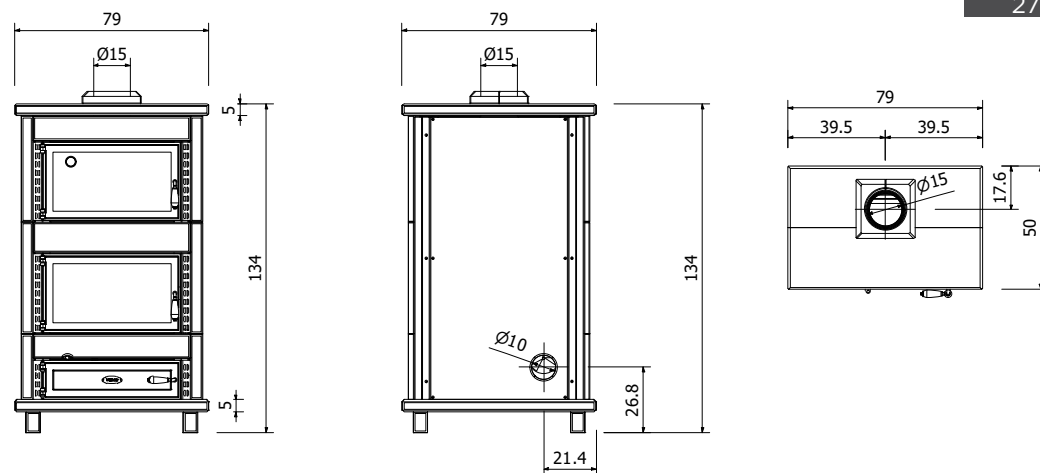

La stufa a legna Aurina Maxi, con il suo elegante e robusto rivestimento in pietra serpentino, offre non solo un design sofisticato ma anche un'eccezionale capacità di accumulo e distribuzione del calore. Il focolare spazioso, realizzato in ghisa, permette l'inserimento di ceppi di legna fino a 50 cm, garantendo ore di fuoco prolungate e un riscaldamento uniforme anche nelle giornate invernali più rigide.

The Aurina Maxi woodstove, with its elegant and sturdy serpentine stone cladding, offers not only a sophisticated design but also exceptional heat storage and distribution capacity. The spacious cast iron firebox accommodates logs up to 50 cm in length, ensuring prolonged burning hours and even heating, even on the coldest winter days.

Le poêle à bois Aurina Maxi, avec son élégant et robuste revêtement en pierre serpentine, offre non seulement un design raffiné, mais aussi une capacité exceptionnelle d'accumulation et de diffusion de la chaleur. Le foyer spacieux en fonte permet d'introduire des bûches jusqu'à 50 cm, garantissant des heures de combustion prolongée et un chauffage uniforme, même pendant les journées d'hiver les plus rigoureuses.



SPB 025



453 kg



9,2 kW



180-320 m³



15 Ø cm



11,9 Pa



82,7 %



A+



ghisa
cast iron / fonte31 cm
51 cm — 26 cm27 cm
40 cm — 28 cm

PB PS



2,6 kg/h – cm 33/50

OPTIONAL

VF



CP





AURINA
PIETRA BOCCIARDATA



AURINA
PIETRA SABBBIATA



VENETIEN



CRETA



VALTELLINA

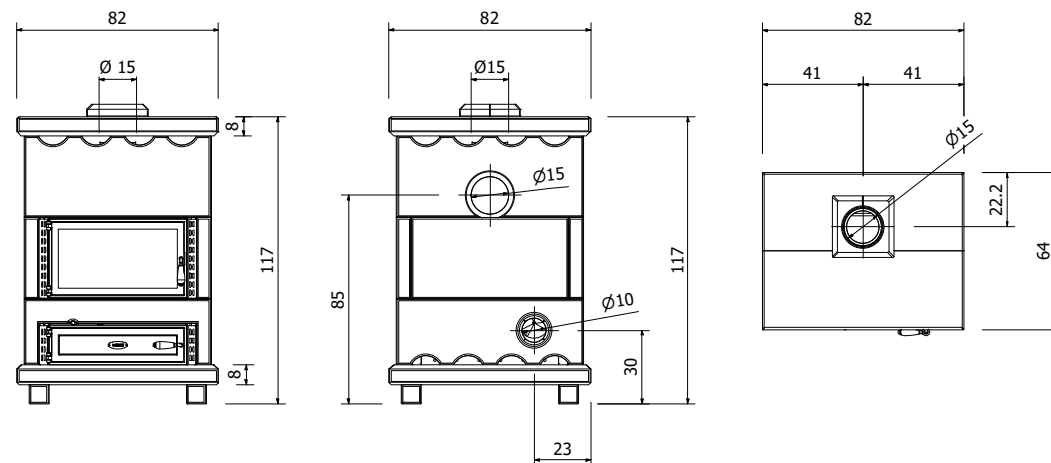

Magnifica e potente stufa a legna. Il rivestimento massiccio in pietra serpentino bocciardato e il decoro realizzato da mani esperte, ne fanno opere d'arte "su misura" per clienti che apprezzano prodotti senza tempo. Il grande focolare può contenere ceppi fino a 50 cm. La grande massa di accumulo garantisce un sano e piacevole calore per oltre 10/12 ore.

A gorgeous and powerful woodstove. Its massive hammered serpentine cladding and its decor made by skilled hands make it a "tailor-made" artwork for customers appreciating timeless products. Its large firebox can contain logs up to 50 cm. Its great accumulation mass guarantees a healthy and pleasant warmth for over 10/12 hours.

Poêle à bois magnifique et puissant. Le revêtement en pierre serpentine massive bouchardée et la finition réalisée par des main expertes en font une œuvre d'art sur mesure pour des clients qui apprécient les produits intemporels. Son grand foyer peut contenir des bûches jusqu'à 50 cm. La grande masse d'accumulation assure une chaleur saine et agréable pendant plus de 10/12 heures.

🔥 SPB 023											
📊 Kg	738 kg										
⚡ kW	9,2 kW										
m ³	180 ÷ 320 m ³										
🔥	15 Ø cm										
⬇️⬆️	11,9 Pa										
η	82,7 %										
🏠	A+										
DM 186	★★★★										
🔥	ghisa cast iron / fonte 33 cm 50 cm ↙ 35 cm										
📄	PB PS										
🔥	2,6 kg/h – cm 33/50										
OPTIONAL	<table border="1"> <tr> <td>VF</td> <td>CP</td> <td>👉</td> <td></td> <td></td> </tr> <tr> <td>×</td> <td>×</td> <td>✓</td> <td></td> <td></td> </tr> </table>	VF	CP	👉			×	×	✓		
VF	CP	👉									
×	×	✓									

PORTALEGNA

LOG STACKERS / PORTE-BÛCHES



PL 2-P8

NERO
BLACK
NOIR

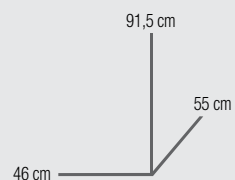

PL 3-P8

NERO
BLACK
NOIR

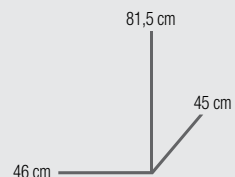

N.B.: I PORTALEGNA PL2 E PL3 SONO DISPONIBILI NEI COLORI GRIGIO E NERO
N.B.: PL2 E PL3 LOG STACKERS ARE AVAILABLE IN GREY OR BLACK COLOUR
NB: LE SUPPORT DE BOIS PL2 ET PL3 SONT DISPONIBLES EN GRIS ET NOIR

PIASTRE

FIREPROOF PAD / PLAQUES



PIASTRA NERA D'APPOGGIO
BLACK FIREPROOF PAD
PLAQUE NOIR APPUI

MANIGLIE

HANDLES / POIGNÉES



MANIGLIA IN OTTONE
PORCELLANA NERA

BRASS AND BLACK
PORCELAIN HANDLE

POIGNÉE LAITON
PORCELAINE NOIRE



MANIGLIA INOX
PORCELLANA AVORIO

STAINLESS STEEL AND
IVORY PORCELAIN
HANDLE

POIGNÉE LAITON
PORCELAINE IVOIRE



MANIGLIA INOX
PORCELLANA BIANCA

STAINLESS STEEL AND
WHITE PORCELAIN
HANDLE

POIGNÉE LAITON
PORCELAINE BLANCHE

ACCESSORI

ACCESSORIES / ACCESSOIRES



PIASTRELLE 10 X 10 PER STUFE

10 X 10 TILES FOR STOVES / 10 X 10 CARREAUX POUR PÔÊLES



CD 140



CD 100

CROCO
CD 100

CD 190

CROCO
CD 190

CD 120

CROCO
CD 120

CILIEGIA

CD 150



CD 150

2



CD 150

8



CD 150

12



CD 170

10



CD SK 07

CROCO ARANCIO



CD 150

5

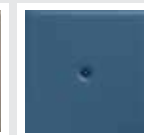
M 3
TORTORAM 10
AZZURROM 6
AVORIOM 11
SABBIA MATT.M 7
BIANCOM 12
CARTA DA
ZUCCHEROM 9
GRIGIO FUMOM 13
VERDE
CHIARO

RIVESTIMENTI COVERINGS / REVÊTEMENTS

M MAIOLICA STUFE

MAJOLICA / MAJOLIQUE



PB DECORI PER STUFE IN PIETRA BOCCIARDATA

TRIM FOR STOVES IN BUSH-HAMMERED STONE / DÉCORS POUR POÊLES EN PIERRE BOUCHARDÉE



DECORI PER "AURINA"
TRIM FOR "AURINA"
DÉCORS POUR "AURINA"



La pietra serpentino utilizzata da Wekos per rivestire le proprie stufe è una pietra naturale grigia con sfumature di colore verde che viene estratta e lavorata in Valmalenco provincia di Sondrio – Italia. Questa pietra ha la capacità di accumulare calore che rilascia poi lentamente anche a stufa spenta creando un ambiente confortevole e sano.

The serpentine used by Wekos for facing its stoves is a natural grey stone with green undertones. It is extracted and processed in Valmalenco located in the Province of Sondrio – Italy. This stone has the ability to absorb heat and radiate it slowly even with the stove off, thus creating a comfortable and healthy environment.

La pierre serpentine utilisée par Wekos pour le revêtement de ses poêles est une pierre naturelle grise avec des nuances vertes. Cette pierre est extraite et taillée à Valmalenco, dans la province de Sondrio (Italie du Nord). Cette pierre a la possibilité d'accumuler la chaleur qui rayonne lentement par la suite, même lorsque le poêle est éteint, créant ainsi une atmosphère confortable et saine.

SCHEMI DI STUFE WEKOS CON VENTILAZIONE FORZATA

SCHEMES OF WEKOS' STOVES WITH FORCED AIR VENTILATION SYSTEMS
SCHÉMAS DE POÊLES WEKOS AVEC VENTILATION FORCÉE

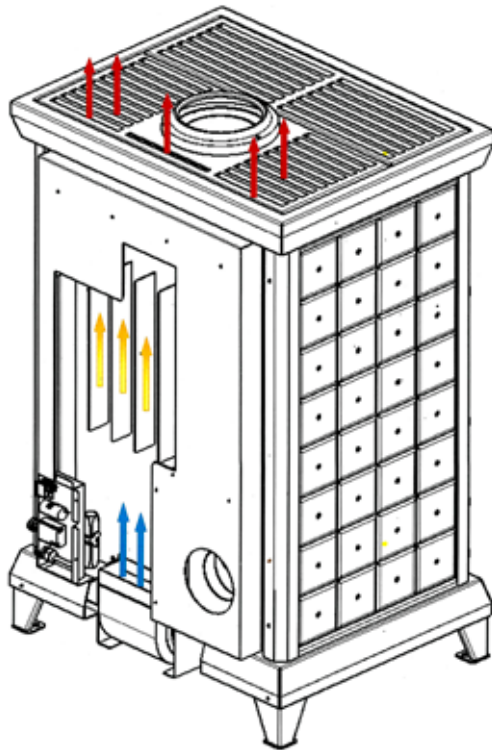

Esempio di stufa con ventilazione forzata.

Example of stove with forced air ventilation system.

Exemple de poêle avec ventilation forcée.

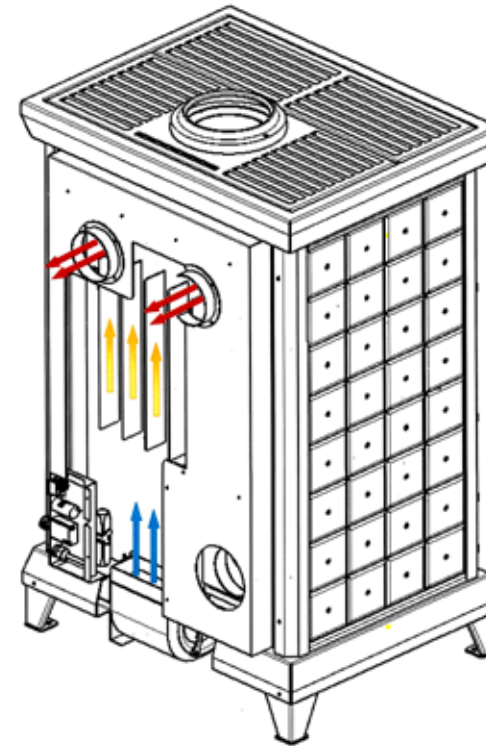

Esempio di stufa con ventilazione forzata e convogliazione aria posteriore. Si possono mettere 1 o 2 bocchette diametro 120 mm.

Example of stove with forced air ventilation system and rear air conveyor. It can be equipped with 1 or 2 120 mm diameter vents.

Exemple de poêle avec ventilation forcée et convoyage air postérieure. Il peut être équipé de 1 ou 2 buses de 120 mm de diamètre.

WEKOS

Rev. 04/2025

Tutti i dati tecnici sono indicativi. L'azienda costruttrice si riserva di apporre modifiche senza alcun preavviso.

All technical data are indicative. The manufacturer reserves the right to make changes without prior notice.

Toutes les données techniques sont indicatives. Le constructeur se réserve le droit d'apporter des modifications sans aucun préavis.

MADE IN ITALY

LIME&Co.

WEKOS

WEKOS S.r.l.

Via dell'Industria, 18
37066 Sommacampagna (Verona)
Tel. +39 045 8960108
Fax +39 045 8960725
www.wekos.it - wekos@wekos.it

